

WMF Coffee Machines

WMF Planning Info Cup Dispenser Presto & Bistro

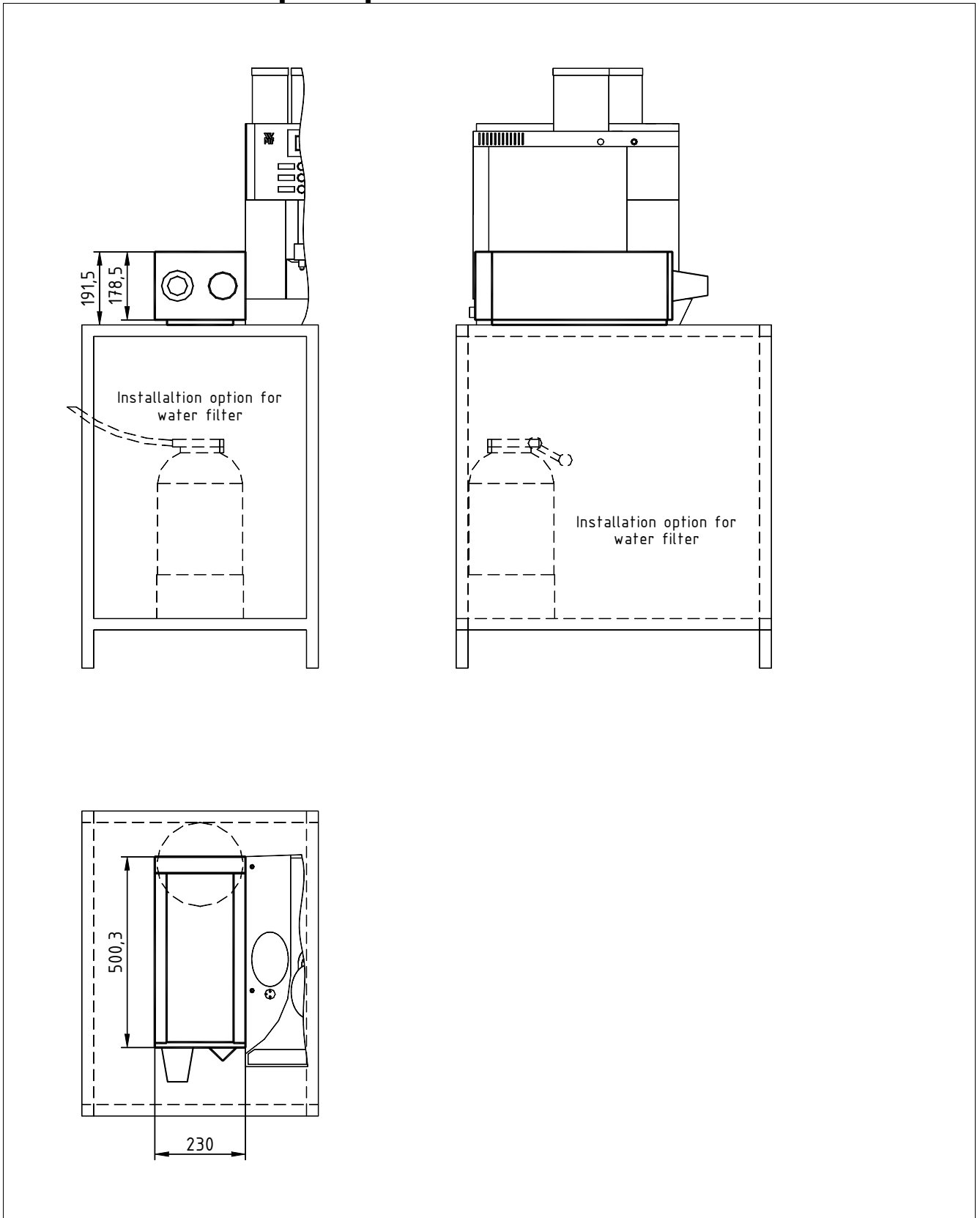

WMF Coffee Machines

WMF Planning Info

Cup Dispenser and Auxiliary Cooler 6,5 L Presto & Bistro

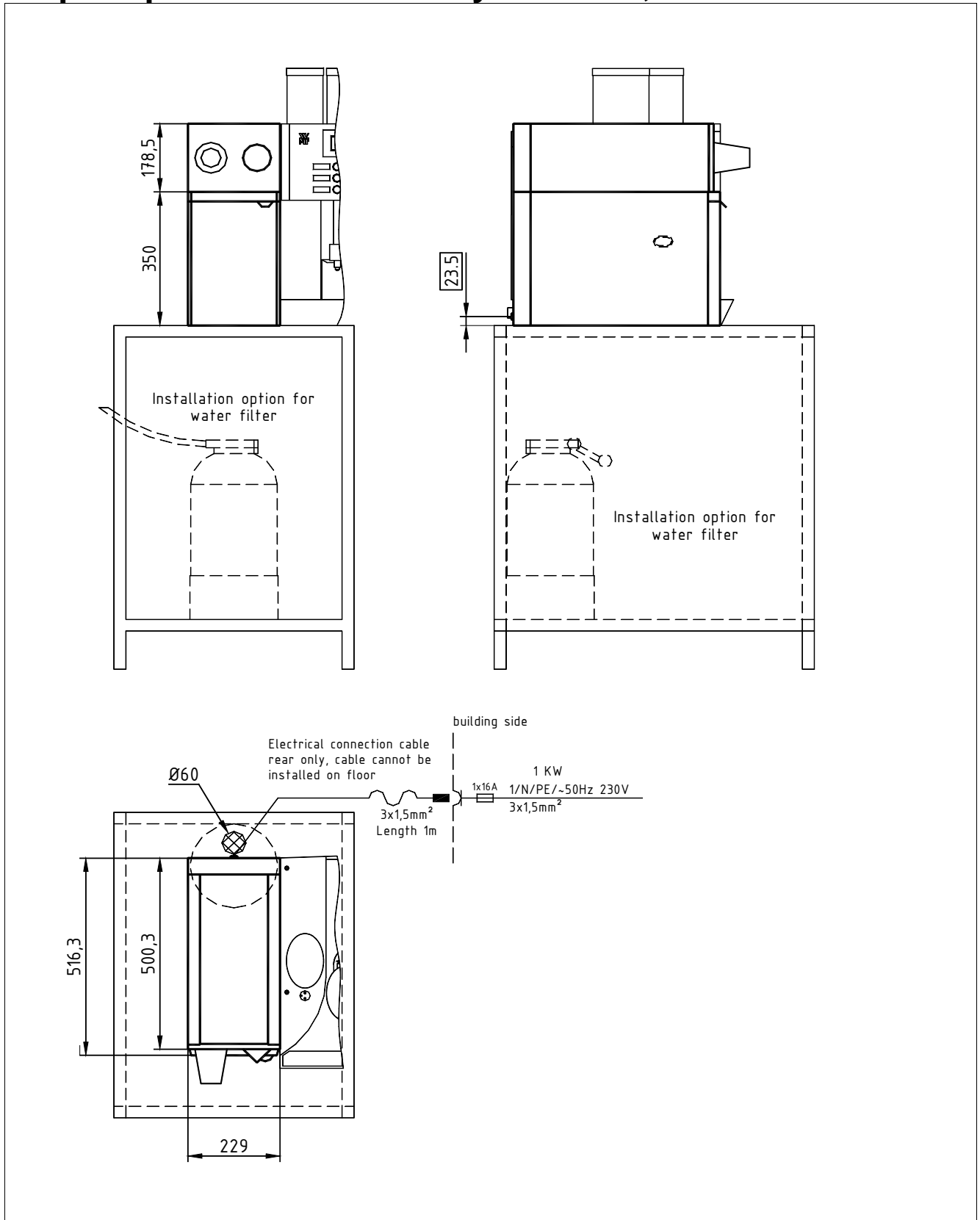

WMF Coffee Machines

Data sheet for Cup Dispenser and Auxiliary Cooler Bistro/Presto Design

Type:	03 9199 0009 Cup Dispenser usable for cups from 60 mm Ø to 90 mm Ø. Accessory device for WMF Presto or WMF Bistro
Capacity:	Stack length per tube approx. 420 mm
Miscellaneous:	The cup dispenser can be used either as a stand-alone unit, or together with a WMF coffee machine, or as an accessory device installed left-hand side of the WMF coffee machine together with the WMF countertop cooler 9192. To increase cup capacity several cup dispensers can be stacked up.
Accessories:	2 each membranes suitable for cups Ø 60 -74 mm, 75 - 82 mm and 83 - 90 mm
Empty weight:	approx. 5 kg
Type:	03 9192 0001 Auxiliary Cooler for WMF Presto or WMF Bistro Series, 1 / N / PE, 50Hz, 230V, 0,09 KW, fuse protection building 16 A,
Capacity:	Milk container 6,5 L, including lid equipped with Plug & Clean-connection and Plug & Clean hose adapter. Cooling temperature individually adjustable from +2° C to +6° C
Option:	Lockable front door for self-service operation.
Degree of protection:	IPX0
Protection class:	Protection class I
Perceptible heat emission:	0,015 KWh/h in medium mode
Continuous sound pressure level (Lpa)	<60 dB (A)
Miscellaneous:	The auxiliary cooler can only be installed on the left viewed from the server side of the coffee machine, connecting cable 1.4 m long, On/Off switch.
Empty weight:	16,5 kg
Installation clearances:	<p>For the installation a minimum clearance of 50 mm to the back wall and at the sides to walls or other non-WMF equipment is required for functional, service and safety reasons.</p> <p>A clear height of 1100 mm from the top of the installation area is required. The height of the installation area from the top of the floor should be at least 700 mm and a maximum of 900 mm.</p> <p>Installation of accessories underneath the unit (such as water filter or sediment separator) requires a clearance of 550 and 695 mm, depending on the configuration and the local installation conditions.</p> <p>If the connections of the machine are down through the counter, please also consider the space required by the connection lines, which may restrict the usable space in the substructure.</p>
Electrical connection:	<p>The following specifications for the electrical connection and the cited standards are applicable for connecting machines in EU countries. If applicable, additional national regulations must be observed. Outside the EU the acceptance of the cited standards must be checked by the persons who market the machines.</p> <p>The building electrical system must comply with IEC 364. For increased safety the device should be protected by an earth-leakage circuit breaker with 30 mA rated fault current (EN 61008). A standard electrical outlet compliant with EN 60309 must be installed near the device or 30 cm below the top of the counter at the back or side of the undercounter structure for a single-phase connection. If the power connection cord of this device has been damaged, it must be replaced by our customer service or by a similarly qualified person. The power cord must not be in contact with hot objects. The electrical outlet is part of the building installation. The machine must not be installed with a fixed building connection when used with a trolley (mobile station).</p>

