

WMF COFFEE MACHINES

WMF planning info combiNATION E, 8600 series

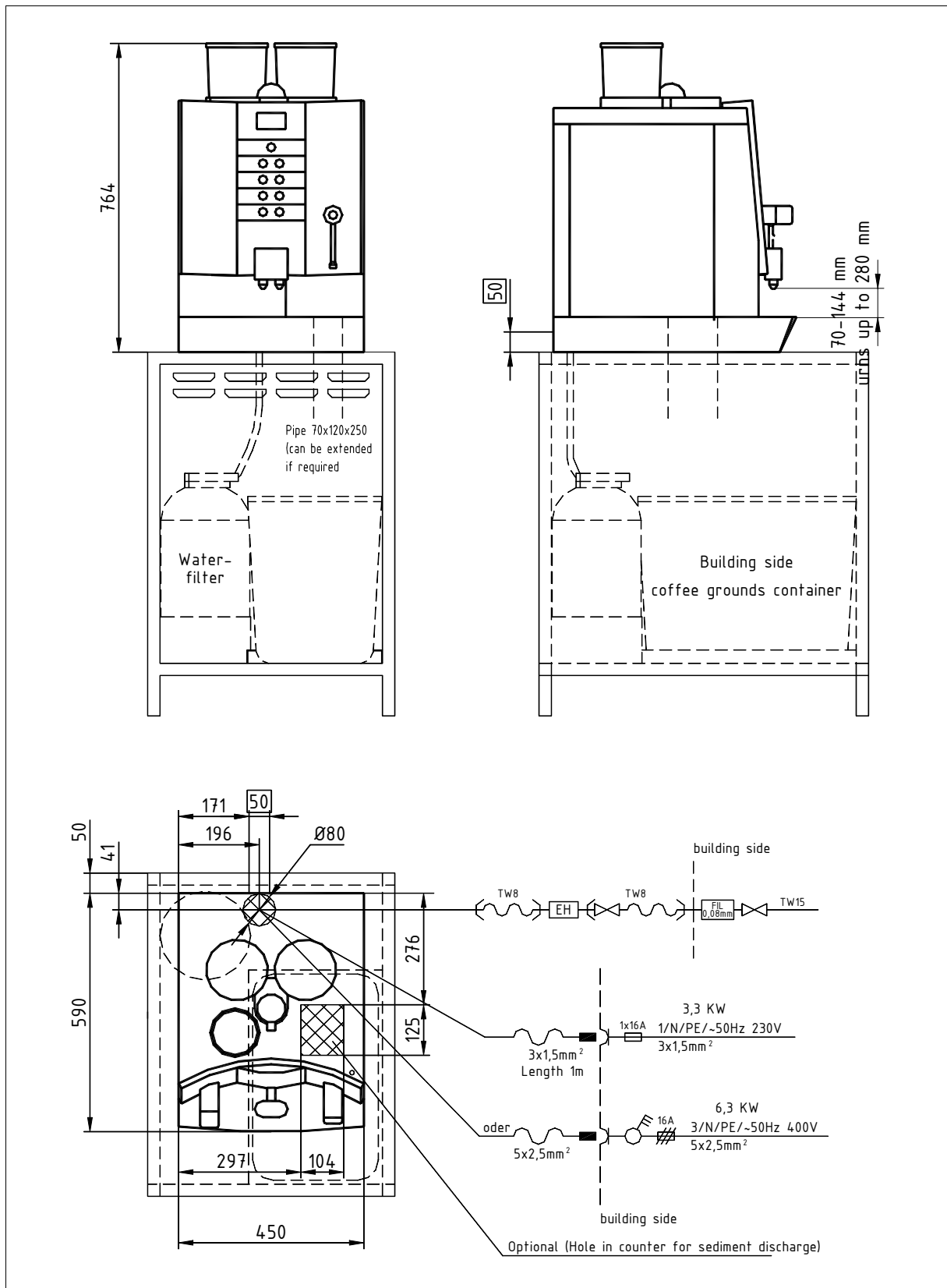

WMF Aktiengesellschaft Vertrieb Kaffeemaschinen
 D-73309 Geislingen/Steige Germany
 Tel. 0 73 31 - 25 71 98
 E-mail: Gastronomie@wmf.de
 Order No. 63 8460 0390

Fax 0 73 31/25 72 95

Internet: <http://www.wmf.de>

WMF COFFEE MACHINES

Data sheet for combiNation S

Base models: other types different from the base models can be combined with the modular structure of the combiNation S series.	03 8600 2050 aluminium design	1 / N / PE, 50Hz, 230V, 3.3 kW, fuse protection building 16 A 1 coffee grinder, steam, hot water dispenser, integrated double milk foamer with automatic rinsing,
	03 8600 2051 beech design	3 / N / PE, 50Hz, 400V, 6.3 kW, fuse protection building 3x16 A, 1 coffee grinder, steam, hot water dispenser, integrated double milk foamer with automatic rinsing,
	03 8600 2053 basic	1 / N / PE, 50Hz, 230V, 3.3 kW, fuse protection building 16 A 1 coffee grinder, steam, hot water dispenser, integrated double milk foamer with automatic rinsing,
	Design rear panels in basic, aluminium, beech or anthracite design on request	
Brewing process:	specialty coffees with and without milk resp. milk foam	
Output per hour:	3,3 kW 300 cups Espresso, 200 cups Café Crème, 24 L hot water 6,3 kW 300 cups Espresso, 240 cups Café Crème, 48 L hot water	
Option:	Power supply 6,3 kW (400V/50/3/N/PE), additional coffee grinder, Jetfunction, steam nozzle, cashless billing with cards or bank card reader or coin checker/coin changer (WMF housing modules available)	
Accessories:	water softener, cupboard, milk refrigerator, chocolate dispenser, sediment trap on building side	
Degree of protection:	IPX0	
Protection class:	Protection class I	
Perceptible heat emission:	0.12 kWh/h in standby mode for all types with rated power 3.3 kW 0.09 kWh/h in standby mode for all types with rated power 6.3 kW	
Perceptible heat emission:	3.2 kWh/h in maximum mode for all types with rated power 3.3 kW 6.2 kWh/h in maximum mode for all types with rated power 6.3 kW	
Continuous sound pressure level (Lpa)	< 67 dB (A)	
Water connection:	1/2" (TW 15)	
Flow pressure:	at least 0.2 MPa, at 2 L min., maximum 0.6 MPa	
Miscellaneous:	coffee machine with dry residue discharge into an integrated drawer optional with sediment discharge into a building-side container below the counter	
Drain:	DN 19, gradient at least 2%	
Empty weight:	Ca. 80 kg	

WMF COFFEE MACHINES

Installation clearances:

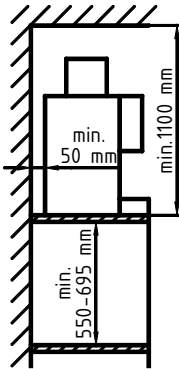

For the installation a minimum clearance of 50 mm to the back wall and at the sides to walls or other non-WMF equipment is required for functional, service and safety reasons.

A clear height of 1100 mm from the top of the installation area is required. The height of the installation area from the top of the floor should be at least 700 mm and a maximum of 900 mm.

Installation of accessories underneath the unit (such as water filter or sediment separator) requires a clearance of 550 and 695 mm, depending on the configuration and the local installation conditions.

If the connections of the machine are down through the counter, please also consider the space required by the connection lines, which may restrict the usable space in the substructure.

Electrical connection:

The following specifications for the electrical connection and the cited standards are applicable for connecting machines in EU countries. If applicable, additional national regulations must be observed. Outside the EU the acceptance of the cited standards must be checked by the persons who market the machines.

The building electrical system must comply with IEC 364. For increased safety the device should be protected by an earth-leakage circuit breaker with 30 mA rated fault current (EN 61008). A standard single-phase electrical outlet or a standard 5-pin three-phase electrical outlet complying with EN 60309 must be installed near the device or 30 cm below the top of the counter on the back or side of the counter. If the power connection cord of this device has been damaged, it must be replaced by our customer service or by a similarly qualified person. If the machine is permanently connected to the building power supply, a circuit breaker that disconnected all poles (main switch) in accordance with EN 60947 must be installed with at least 3 mm contact separation must be installed to protect the machine; the disconnecting device is recommended for a flexible connection. The power cord must not be in contact with hot objects. The main switch and the electrical outlet are part of the building installation. The machine must not be installed with a fixed building connection when used with a trolley (mobile station).

Important information:

To prevent any interference with our shielded data lines by equipotential currents between the devices, an additional equipotential bonding should be installed for devices connected to an accounting system. (IEC 364)

Water feed and drainage:

A sufficiently large, easily accessible stop cock (preferably a ball valve) and a dirt filter with a 0.080 mm mesh must be installed in the water pipe under the counter.

If the drainage connection does not have a sediment separator, the drain must be installed at the rear panel of the bottom cupboard 50 cm from the top of the counter.

A pipe syphon must be installed in the vented drainage pipe. (Fit hose connection in the funnel with a hose ring holder)

The WMF-specific conditions for water, power and effluent must be observed at all times.

For the connection from below through the counter an opening is required in accordance with the drawing (see elevation drawing) or a hole approx. 80 to 120 mm in diameter. Alternatively the connections for electricity, water and drainage can be taken through the body of the machine from the back in the indicated area (see the elevation and side view).

If the water contains more than 5 ppm carbonate, a WMF water filter must be installed.

CAUTION: The static water pressure must not exceed 0.6 MPa (6 bar).

WMF Aktiengesellschaft Vertrieb Kaffeemaschinen
D-73309 Geislingen/Steige Germany

Tel. 0 73 31 - 25 71 98

E-mail: Gastronomie@wmf.de

Order No. 63 8460 0390

Fax 0 73 31/25 72 95

Internet: <http://www.wmf.de>