

WMF COFFEE MACHINES

WMF Planning Info cup & cool combination Design

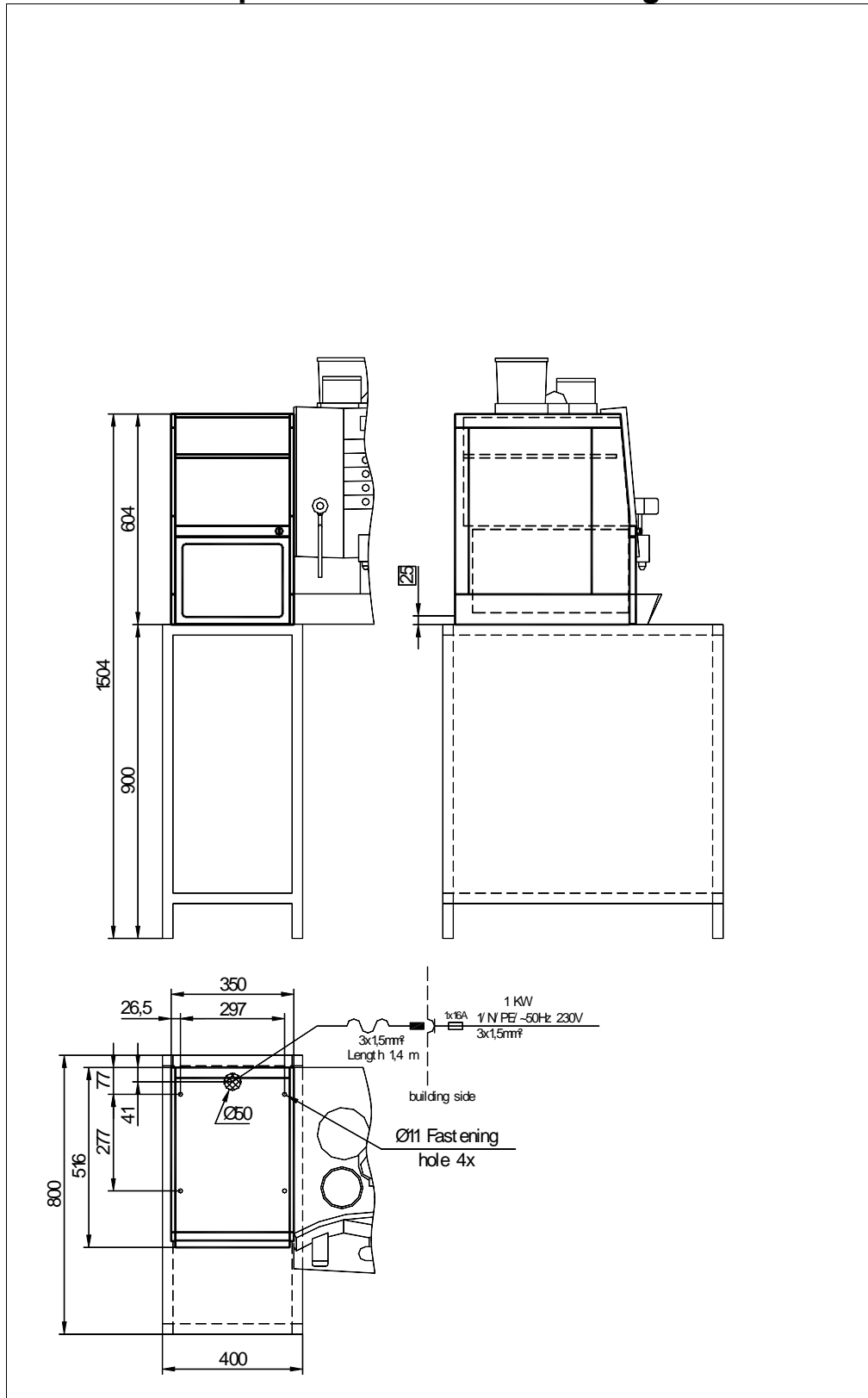

WMF COFFEE MACHINES

Data sheet for cup & cool combiNation Design

Type:	03 9465 0001 cup & cool, combiNation Design, 1 / N / PE, 50Hz, 230V, 0.2 kW, fuse protection building 16 A, (equipped with the existing side parts of the combiNation)
	Design rear panels in basic, aluminium, beech or anthracite design on request
Capacity:	Milk tank: 9.5 litres. Cup shelves: 60 - 90 cups or mugs.
Degree of protection:	IPX0
Protection class:	Protection class I
Perceptible heat emission:	0.138 kWh/h in maximum mode
Continuous sound pressure level	< 49 dB (A)
Miscellaneous:	The WMF combiNation cup and accessory refrigerator can only be installed on the left viewed from the server side of the coffee machine. With automatic refrigeration. Electrically heated cup shelves. Connecting cable 1.4 m long
Empty weight:	32 kg

Electrical connection:	<p>The following specifications for the electrical connection and the cited standards are applicable for connecting machines in EU countries. If applicable, additional national regulations must be observed. Outside the EU the acceptance of the cited standards must be checked by the persons who market the machines.</p> <p>The building electrical system must comply with IEC 364. For increased safety the device should be protected by an earth-leakage circuit breaker with 30 mA rated fault current (EN 61008). A standard electrical outlet compliant with EN 60309 must be installed near the device or 30 cm below the top of the counter at the back or side of the undercounter structure for a single-phase connection. If the power connection cord of this device has been damaged, it must be replaced by our customer service or by a similarly qualified person. The power cord must not be in contact with hot objects. The electrical outlet is part of the building installation. The machine must not be installed with a fixed building connection when used with a trolley (mobile station).</p>
Installation clearances:	<p>For the installation a minimum clearance of 50 mm to the back wall and at the sides to walls or other non-WMF equipment is required for functional, service and safety reasons. A clear height of 1100 mm from the top of the installation area is required. The height of the installation area from the top of the floor should be at least 700 mm and a maximum of 900 mm. Installation of accessories underneath the unit (such as water filter or sediment separator) requires a clearance of 550 and 695 mm, depending on the configuration and the local installation conditions.</p> <p>If the connections of the machine are down through the counter, please also consider the space required by the connection lines, which may restrict the usable space in the substructure.</p>

