

WMF COFFEE MACHINES

WMF Planing Information

Undercounter cooler for combiNation (with coffee grounds discharge)

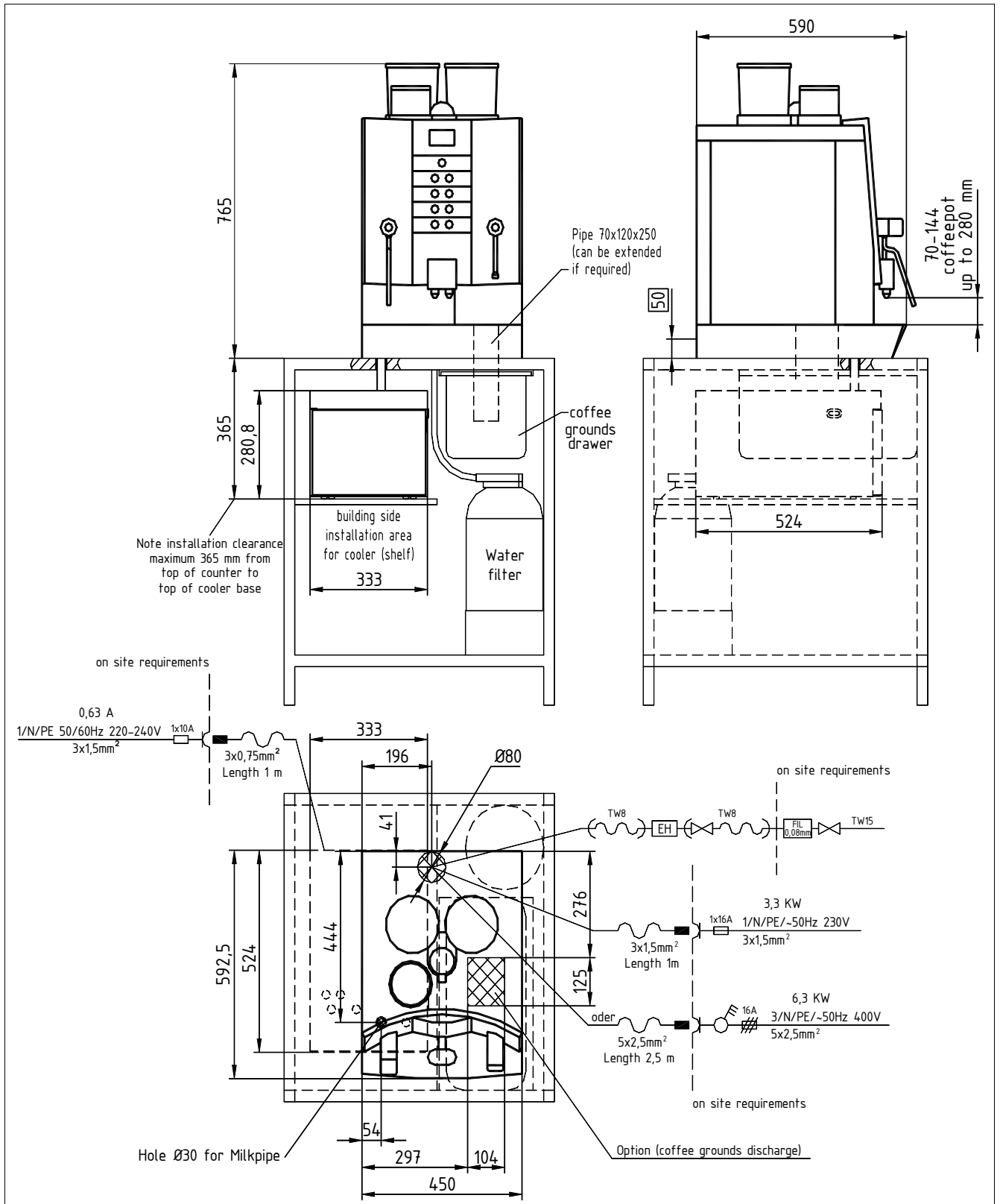

WMF Aktiengesellschaft Vertrieb Kaffeemaschinen
 D-73309 Geislingen/Steige Germany
 Telefon 0 73 31 - 25 97 68
 E-Mail: Gastronomie@wmf.de
 Best. Nr. 63.8445.0390

Telefax 0 73 31/25 81 69
 Internet: <http://www.wmf.de>

WMF COFFEE MACHINES

WMF Planning Information

Undercounter cooler for combiNATION (with integrated coffee grounds drawer)

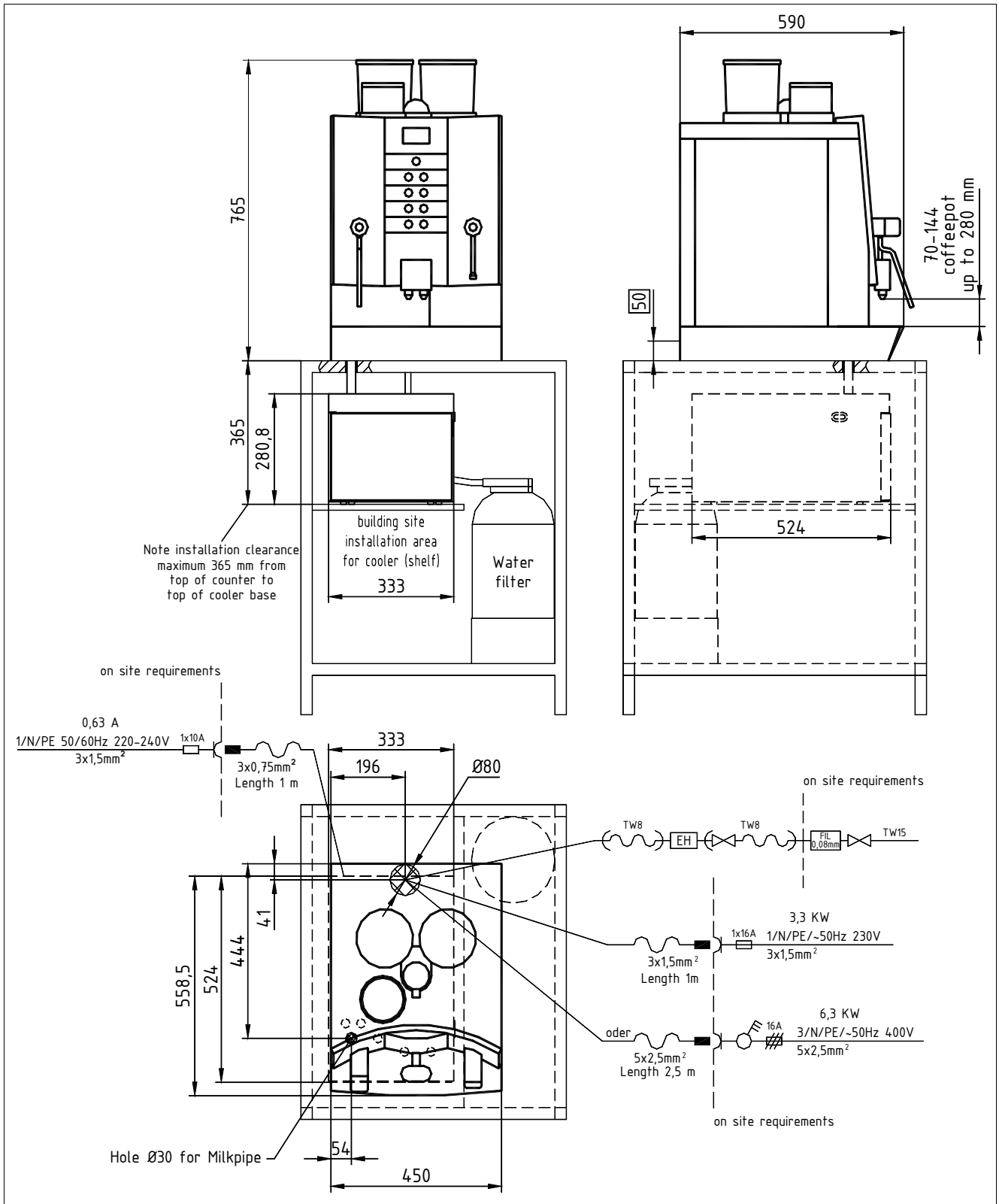

WMF Aktiengesellschaft Vertrieb Kaffeemaschinen
 D-73309 Geislingen/Steige Germany
 Telefon 0 73 31 - 25 97 68
 E-Mail: Gastronomie@wmf.de
 Best. Nr. 63.8445.0390

Telefax 0 73 31/25 81 69
 Internet: <http://www.wmf.de>

WMF COFFEE MACHINES

Data sheet for undercounter cooler for combiNation

Type:	03 9469 2001 undercounter cooler combiNation E, S or S4, 1 / N / PE, 50Hz, 230V, 0.05 kW, fuse protection building 16 A,
Accessories:	WMF pipe sleeve for counter hole.
Capacity:	Milk tank: ca. 9.5 litres
Degree of protection:	IPX0
Protection class:	Protection class I
Perceptible heat emission:	0.04 kWh/h in maximum mode
Continuous sound pressure level (Lpa)	< 43 dB (A)
Miscellaneous:	The installation and operation of the undercounter cooler type 03 9466 0001 is only possible in combination with a WMF combiNation S or S4 specialty coffee machine. Cooler fitted with automatic cooling and separate On/Off switch. Connecting cable 1.4 m long
Option:	Milk empty message (in cas of machine), Plug & Clean in cooler integrated
Ventilation and ambient temperature:	+ 5°C to + 35°C (for passive or active ventilation of the installation space is required if necessary).
Caution: preparation of building for installation	The holes and drilling in the counter top – particularly the 23 Ø mm drilled hole for the pipe sleeve – are building preparations required for installation of the cooler and the connections for the WMF coffee machine. The person ordering the machine is responsible for having this work done by qualified contractors. A shelf must be available under the counter for the cooler – as specified in the installation drawing.
Empty weight:	22,5 kg
Electrical connection:	The following specifications for the electrical connection and the cited standards are applicable for connecting machines in EU countries. If applicable, additional national regulations must be observed. Outside the EU the acceptance of the cited standards must be checked by the persons who market the machines. The building electrical system must comply with IEC 364. For increased safety the device should be protected by an earth-leakage circuit breaker with 30 mA rated fault current (EN 61008). A standard electrical outlet compliant must be installed near the device or 30 cm below the top of the counter at the back or side of the undercounter structure for a single-phase connection. If the power connection cord of this device has been damaged, it must be replaced by our customer service or by a similarly qualified person. The power cord must not be in contact with hot objects. The main switch and the electrical outlet are part of the building installation. The machine must not be installed with a fixed building connection when used with a trolley (mobile station).
Installation clearances:	For the installation a minimum clearance of 50 mm to the back wall and at the sides to walls or other non-WMF equipment is required for functional, service and safety reasons. A clear height of 1100 mm from the top of the installation area is required. The height of the installation area from the top of the floor should be at least 700 mm and a maximum of 900 mm. Installation of accessories underneath the unit (such as water filter or sediment separator) requires a clearance of 550 and 695 mm, depending on the configuration and the local installation conditions. If the connections of the machine are down through the counter, please also consider the space required by the connection lines, which may restrict the usable space in the substructure.

