

WMF COFFEE MACHINES

WMF Planning Info

Storage urn (Warmer) 40 L

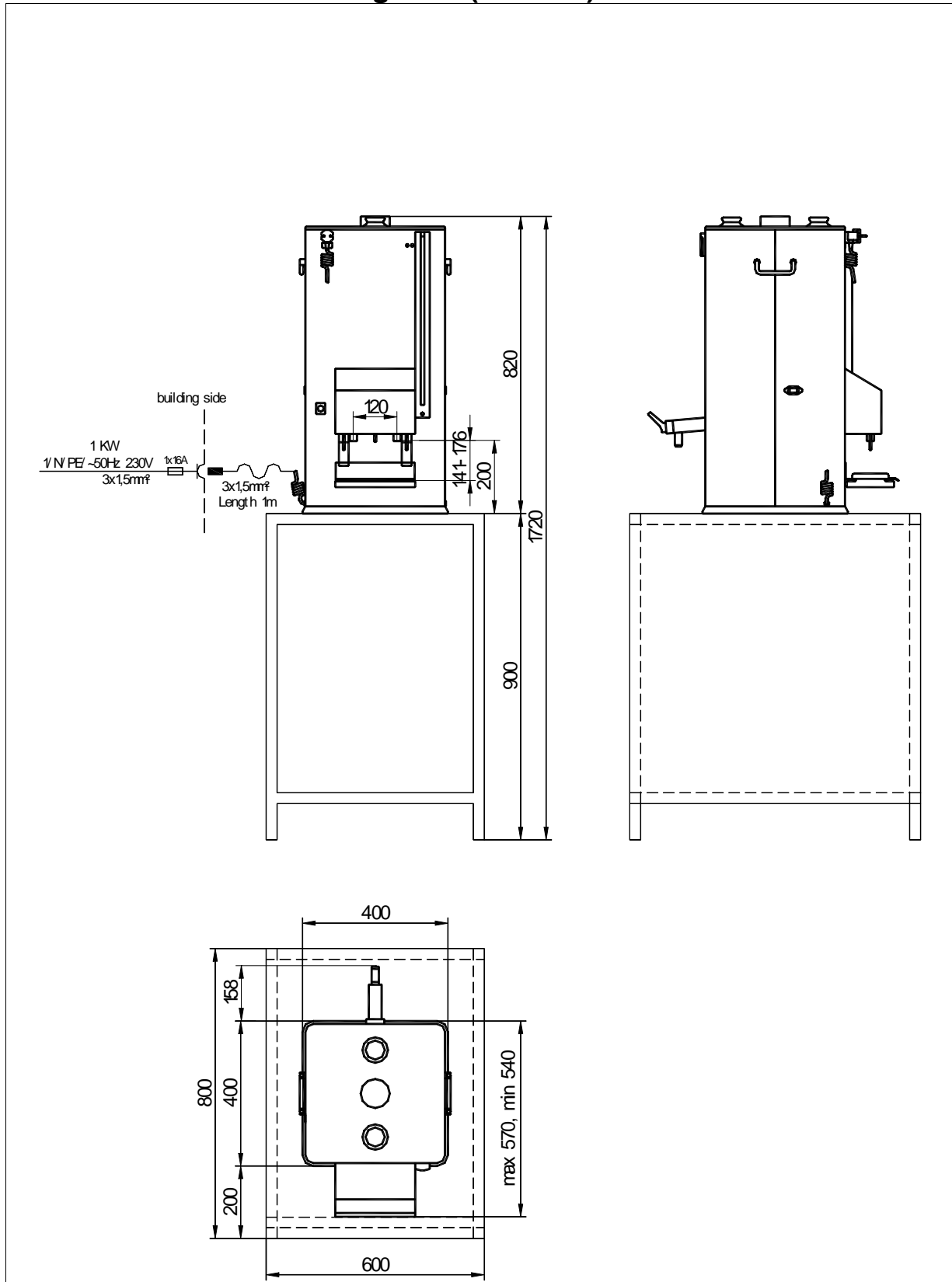

WMF COFFEE MACHINES

Data sheet for storage urn (warmer) 40 L

Type:	03 6440 1001 1 / N / PE, 50Hz, 230V, 0.7 kW, fuse protection building 16 A, automatic double dispensing, dispenser tap on back, automatic after-brewing
Degree of protection:	IPX0
Protection class:	Protection class I
Perceptible heat emission:	0.07 kWh/h in maximum mode
Empty weight:	26 kg
Electrical connection:	<p>The following specifications for the electrical connection and the cited standards are applicable for connecting machines in EU countries. If applicable, additional national regulations must be observed. Outside the EU the acceptance of the cited standards must be checked by the persons who market the machines.</p> <p>The building electrical system must comply with IEC 364. For increased safety the device should be protected by an earth-leakage circuit breaker with 30 mA rated fault current (EN 61008). A standard electrical outlet compliant with EN 60309 must be installed near the device or 30 cm below the top of the counter at the back or side of the undercounter structure for a single-phase connection. If the power connection cord of this device has been damaged, it must be replaced by our customer service or by a similarly qualified person. The power cord must not be in contact with hot objects. The electrical outlet is part of the building installation. The machine must not be installed with a fixed building connection when used with a trolley (mobile station).</p>